



AVK GATE VALVE, FLANGED, 250 PSI/17.2 BAR

45/59-015

ANSI cl. 150 flange drilling, UL/ULC listed/FM approved, post indicator flange and wrench nut, DN50-400

AVK gate valves are designed with built-in safety in every detail. The wedge is fully vulcanized with AVK's own drinking water approved EPDM rubber compound. It features an outstanding durability due to the ability of the rubber to regain its original shape, the double bonding vulcanization process and the sturdy wedge design. The triple safety stem sealing system, the high strength stem and the thorough corrosion protection safeguard the unmatched reliability.

Product description:

Flanged gate valve with post indicator flange, UL/FM approved. For fire protection applications to max. 70° C

Standards:

- Designed according to AWWA C509, Designed according to FM 1120/1130, UL 262
- Face-to-face dimension according to ANSI B16.10
- Flange drilling to ANSI B 16.42, class 150

Test/Approvals:

- Hydraulic tests according to FM and UL Standards.
- Seat: 1.5 x PN (in Bar). Body: 2 x PN (in Bar). Closing torque test.
- FM Approved. UL listed.

Features:

- Fixed, integral wedge nut prevents vibration and ensures durability
- Wedge fully vulcanized with drinking water approved EPDM rubber and equipped with wedge shoes to provide smooth operation
- Large conical stem hole in the wedge prevents stagnant water
- Wedge and body guide rails ensure stable operation
- Stainless steel stem with rolled threads for high strength
- Full circle thrust collar provides fixation of the stem and low free running torques
- Triple safety stem sealing with an NBR wiper ring, a polyamide bearing with four NBR O-rings, and an EPDM rubber manchette
- Round EPDM bonnet gasket fixed in a recess
- Countersunk and sealed stainless steel bonnet bolts encircled by the bonnet gasket
- Full bore
- Low operating torque
- Fusion bonded epoxy coating in compliance with DIN 3476 part 1 and EN 14901

Accessories:

Post indicator, wall post indicator



Expect... **AVR**

The designs, materials and specifications shown are subject to change without notice. This is due to the continuous development of our product programme.

AVK GATE VALVE, FLANGED, 250 PSI/17.2 BAR

45/59-015

ANSI cl. 150 flange drilling, UL/ULC listed/FM approved, post indicator flange and wrench nut, DN50-400

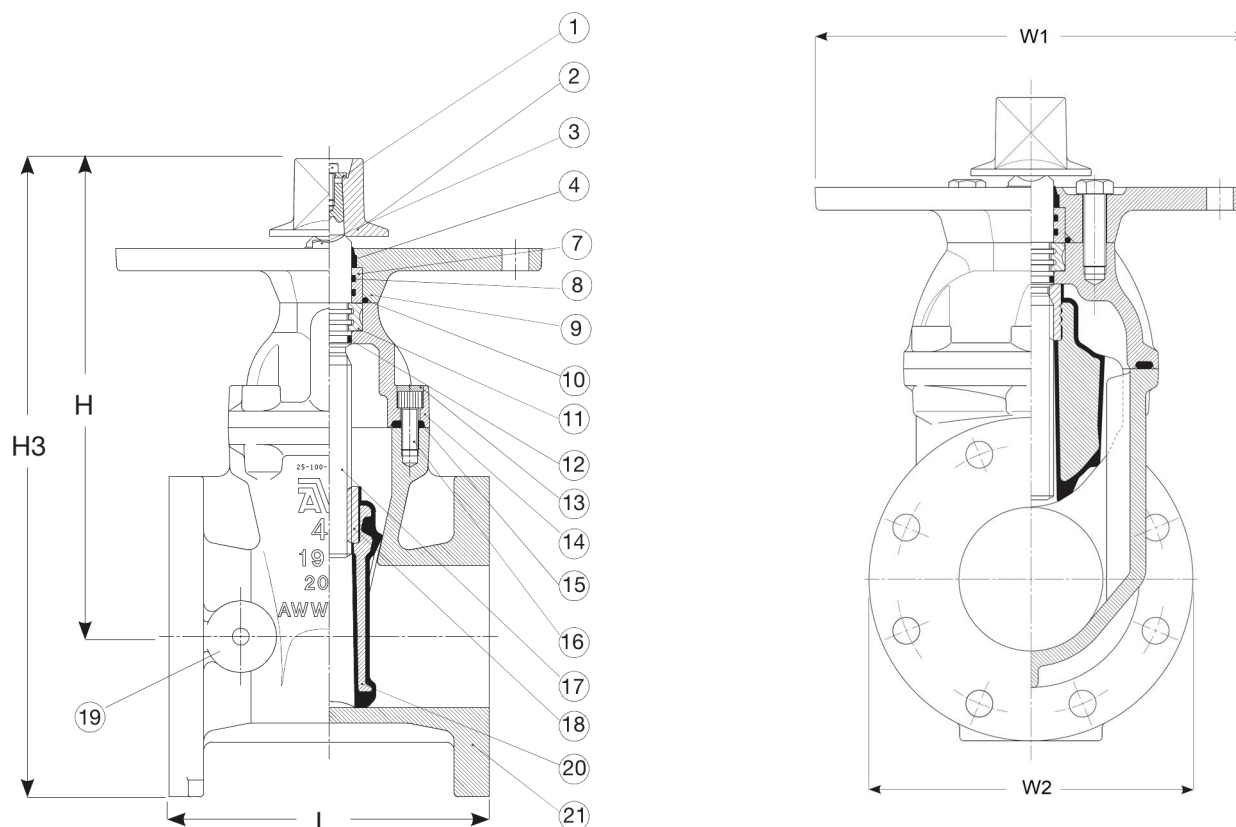

Component list:

1. Bolt	Stainless steel A4	12. Stem seal O-ring	EPDM rubber
2. Wrench nut	Cast iron GJL-250 (GG-25)	13. Bonnet bolt seal	Hot melt glue
3. Washer	Stainless steel A4	14. Bonnet	Ductile iron GJS-500-7 (GGG-50)
4. Wiper ring	NBR rubber	15. Bonnet gasket	NBR rubber
5. Gland flange bolt	Stainless steel A4	16. Bonnet bolt	Stainless steel A4
6. Washer	Stainless steel A4	17. Stem ⁽¹⁾	Stainless steel 304
7. Bushing	Polyamide	18. Wedge nut	Brass, DZR CW602N
8. Stem seal O-ring	NBR rubber	19. Boss	Ductile iron GJS-500-7 (GGG-50)
9. Post indicator flange	Ductile iron GJS-500-7 (GGG-50)	20. Wedge	Ductile iron, EPDM encapsulated
10. O-ring	NBR rubber	21. Body	Ductile iron GJS-500-7 (GGG-50)
11. Thrust collar	Brass, DZR CW602N		

Components may be substituted with equivalent or higher class materials without prior notification.

1) DN350-400: Alu-bronze C63020

Reference nos. and dimensions:

AVK ref. no.	DN	Flange	L	H	H3	W1	W2	Theoretical
	mm	drilling	mm	mm	mm	mm	mm	weight / kg
45-050-59-026141	50	CLASS 150	169	293	383	305	165	25
45-065-59-026141	65	CLASS 150	190	311	394	305	165	29
45-080-59-026141	80	CLASS 150	203	307	403	305	191	32
45-100-59-026141	100	CLASS 150	229	343	458	305	230	36
45-150-59-026141	150	CLASS 150	267	445	585	305	280	51
45-200-59-026141	200	CLASS 150	292	546	718	305	345	77
45-250-59-026B41	250	CLASS 150	330	628	832	305	406	130
45-300-59-026B41	300	CLASS 150	356	701	944	305	483	198
45-350-5D-026B41 ⁽¹⁾	350	CLASS 150	381	899	1158	305	533	350
45-400-5D-026B41 ⁽¹⁾	400	CLASS 150	406	914	1192	305	597	376

(1) Stem in aluminium bronze. 200 PSI/14 bar

The designs, materials and specifications shown are subject to change without notice. This is due to the continuous development of our product programme.